



Installation, inspection & Maintenance Guide 2009



RP404 Typhoon Footing Details

Please read this installation guide in its entirety prior to commencing any installation works

Wetpour Detail

Loose Fill Detail

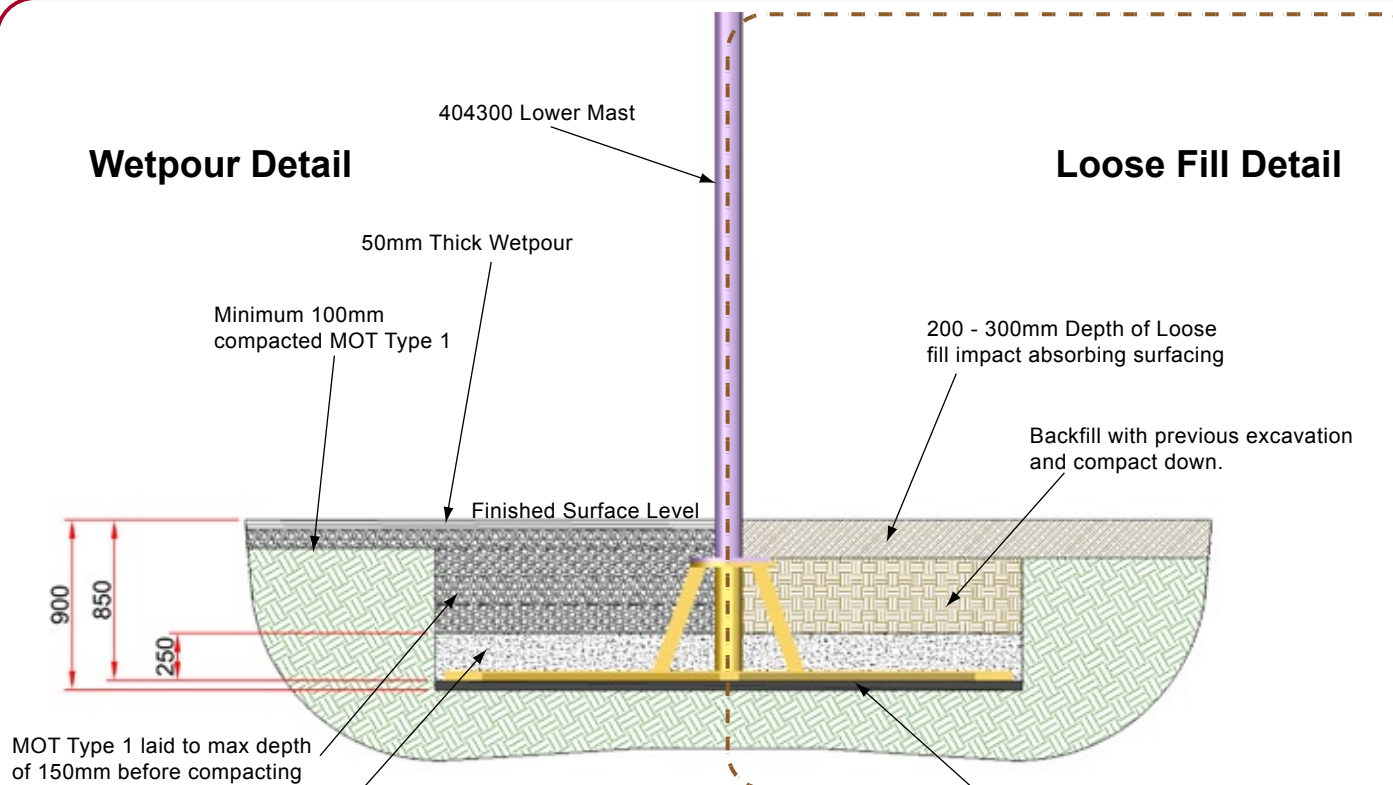

Installation Sequence: -

1. Excavate footings as indicated left
2. Set Typhoon Base unit (404310) into previously excavated foundation, and then attach the Lower Mast (404300) to the base unit using 8 No 10251675 M16 x 75 Hexagonal headed bolts c/w 8 No 10271600 M16 Plain nuts. **Ensure the lower mast is vertical and plumb and the Weld Mark denoting Finished Surface Level is observed**
3. Back fill foundations with 2.4m³ Concrete 4:2:1 mix and allow 60 hours to cure
4. Assemble the rest of the typhoon in line with pages following
5. Following assembly and erection of the Typhoon, for **WETPOUR** surfacing lay compacted type 1 MOT into the rest of the excavation to depths no greater than 150mm prior to compacting down. For **L.I.A.S.** back fill remaining foundation with previous excavation and compact down
6. Fit Seat and chain assemblies (pages 12 & 13) to Wings

Notes: -

- Foundation is assuming good ground conditions, care should be taken concerning abnormal ground conditions
- The Free Height of Fall for Typhoon in 1m
- The Falling Space is Ø11m
- Constructional space requirements are 22m x 12m
- Check tightness of bolts following a 2 week run in period
- Replacement components must comply with Record RSS Ltd specifications
- Ensure level surface on all equipment
- Warning, some of these components exceed the single persons lifting allowance.
- Ensure equipment is protected from usage throughout installation, maintenance and repairs
- Touch-up any damaged paint work
- This installation requires assembly aids which should be removed prior to the equipment being used.

Backfill 4:2:1 Mix.

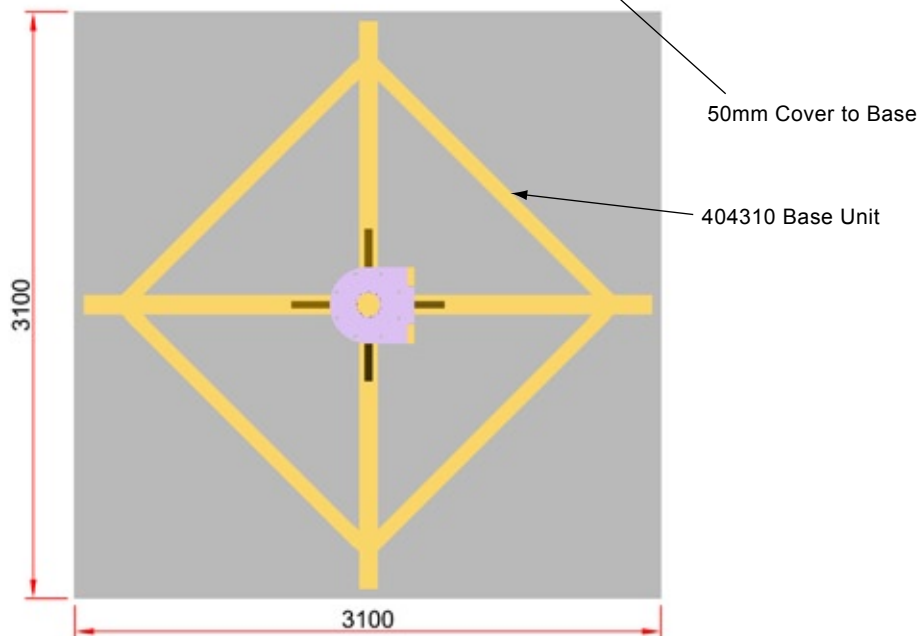

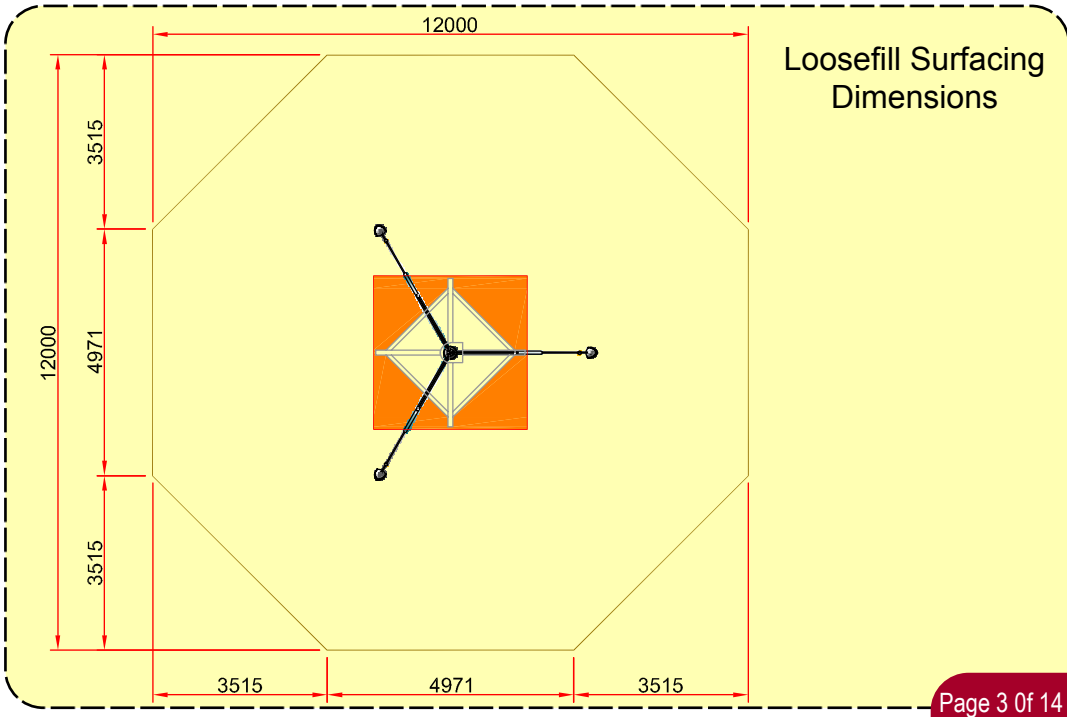
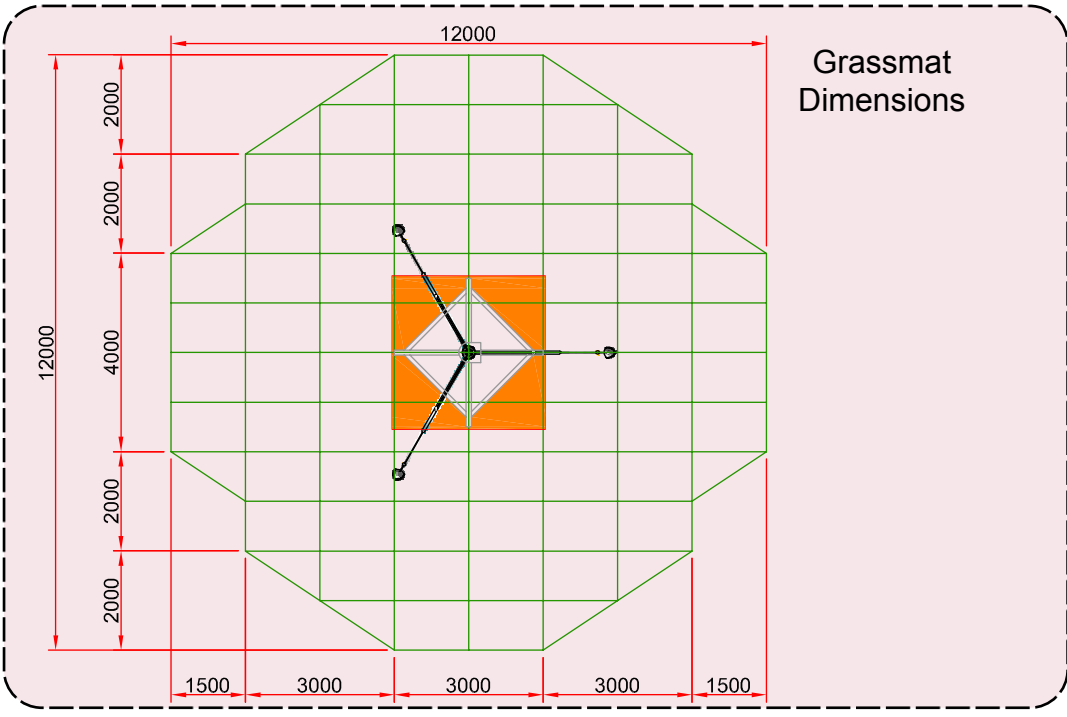
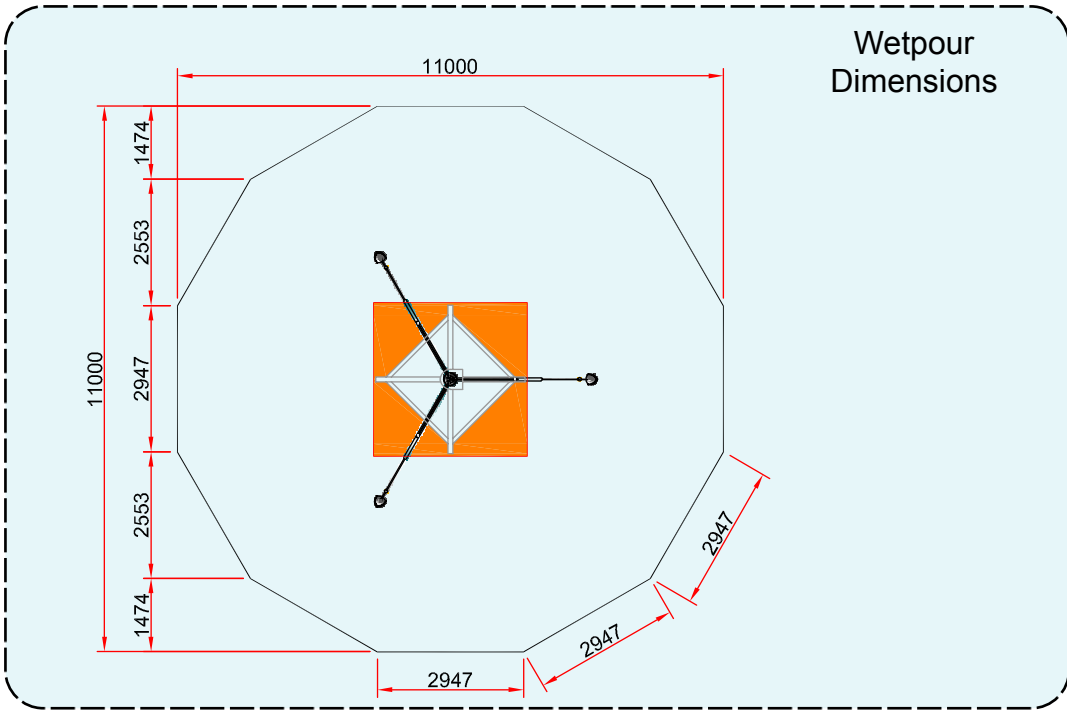
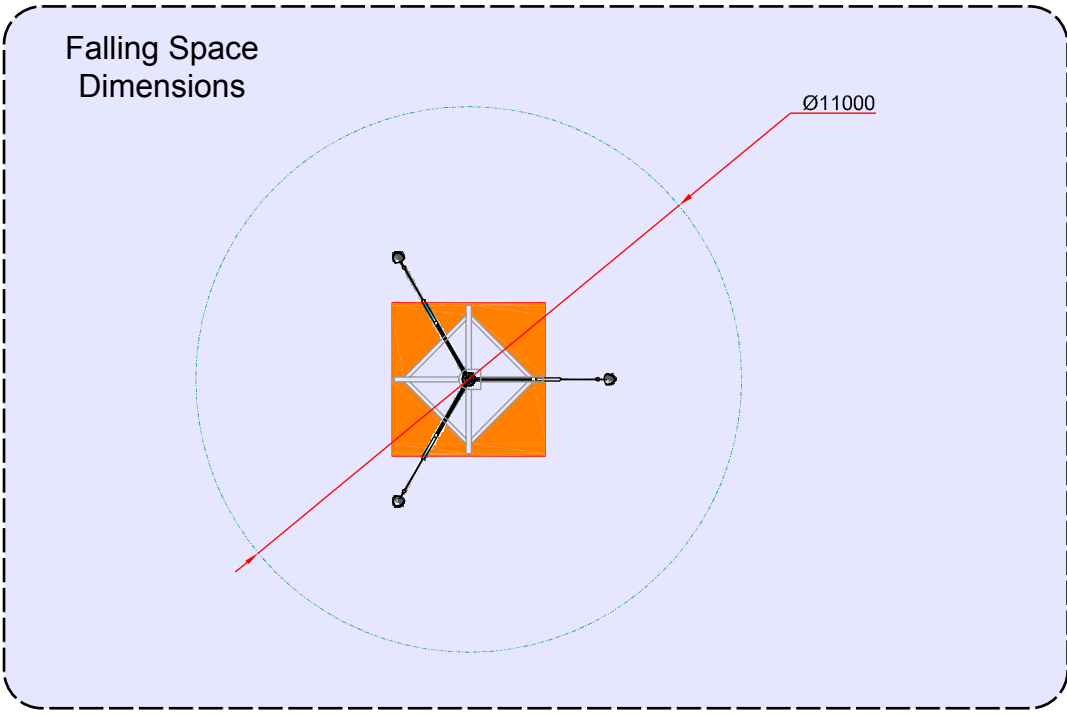

Prepare for assembly: -

1. Allow 60 hours for Concrete to cure then detach lower mast from the Base unit
2. Prepare supports for the Lower and Upper Masts
3. Keep the Lower Masts lower flange above the base unit flange
4. Position wing arm (404302) as illustrated
5. Begin Typhoon assembly in line with the following pages

In order to complete the mechanical aspects of the Typhoon installation, the installer should provide the following items: -

1. Standard tool kit comprising of a selection of open ended spanners and sockets suitable for nuts up to M16 & M20.
2. Torque wrench suitable for applying the following settings: -
 - a. 150 Nm for M12 x 70 12.9 tensile grade fasteners
 - b. 200 Nm for M16 x 75 8.8 tensile grade fasteners
3. Suitable spirit level for checking trueness of base flange (horizontal) and column (vertical)
4. 6-metre extension ladder for accessing upper column rope connections
5. Safety harness for working at heights
6. Ladder adaptor to support upper portion of extension ladder against vertical column when accessing upper rope connections
7. 3.5 metre steps for accessing wing arm connections.
8. Tube of medium strength (blue) nut lock.
9. Pulling Machine – minimum-pulling capacity of 1.2 metric tonnes complete with 20 metres of wire rope.
10. One 2 tonne “D” shackle for attaching to lifting device.
11. Two slings each rigged separately to provide a 2 metric tonne pull
12. Grease for lubricating lower column hinge during installation.
13. Caution tape to clearly delineate safe working areas.

Position Lower Mast Base Flange
above Base unit flange

Support the
Lower Mast

Support the
Upper Mast



RP404 Typhoon - Halo Ring Assembly

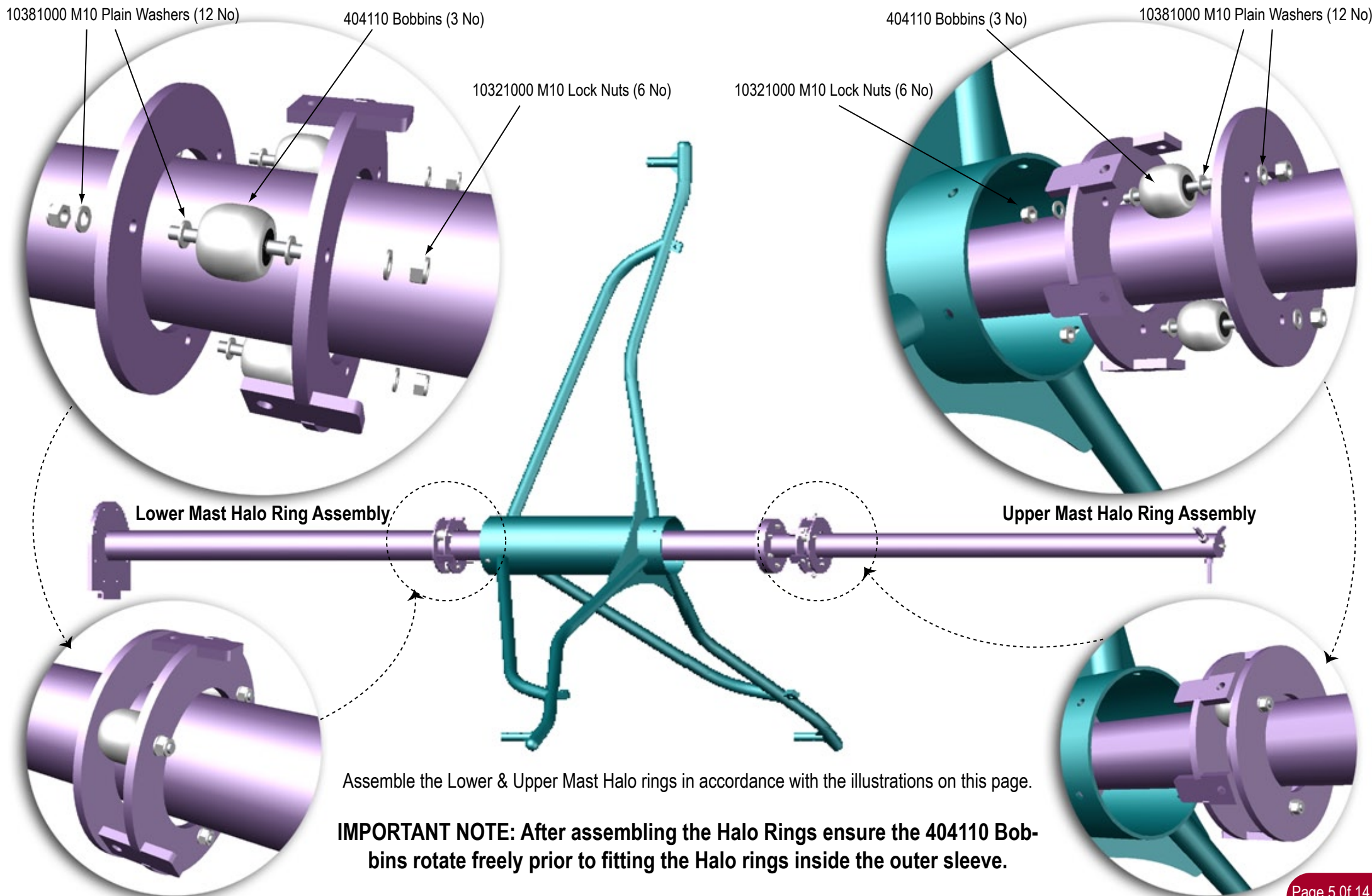

Assemble the Lower & Upper Mast Halo rings in accordance with the illustrations on this page.

IMPORTANT NOTE: After assembling the Halo Rings ensure the 404110 Bobbins rotate freely prior to fitting the Halo rings inside the outer sleeve.



RP404 Typhoon - Mast Assembly

Using Torque Wrench tighten fixings to 150 Nm.

404300 Lower Mast
10251271 M12 x 70 Hex Head Bolts c/w 10291200 Washers

10321200 M12 Lock Nuts c/w Washers

404301 Upper Mast

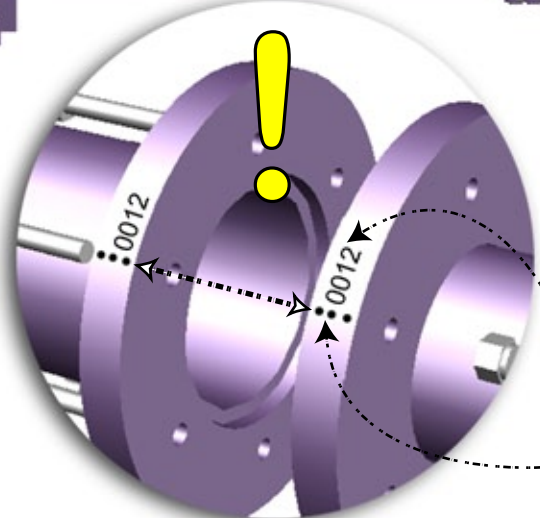
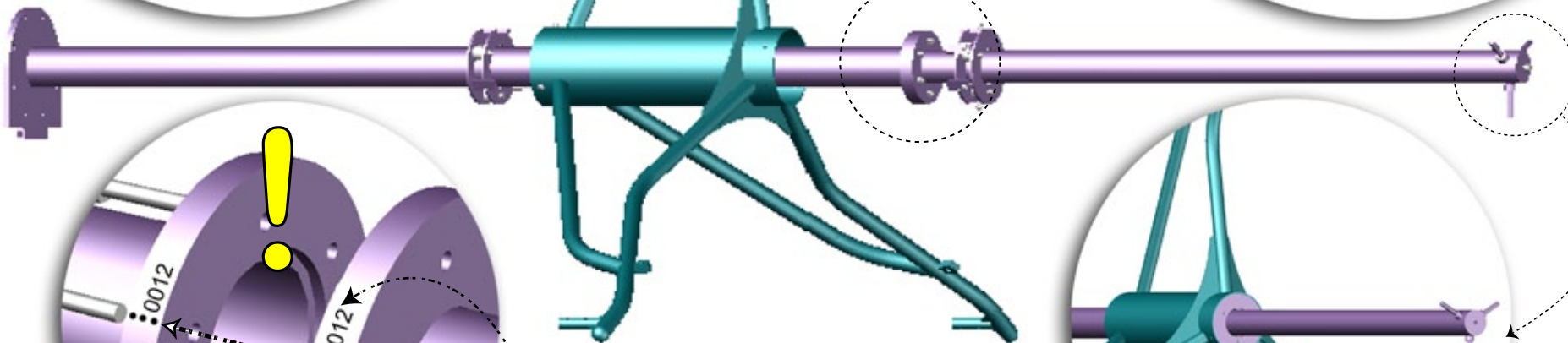
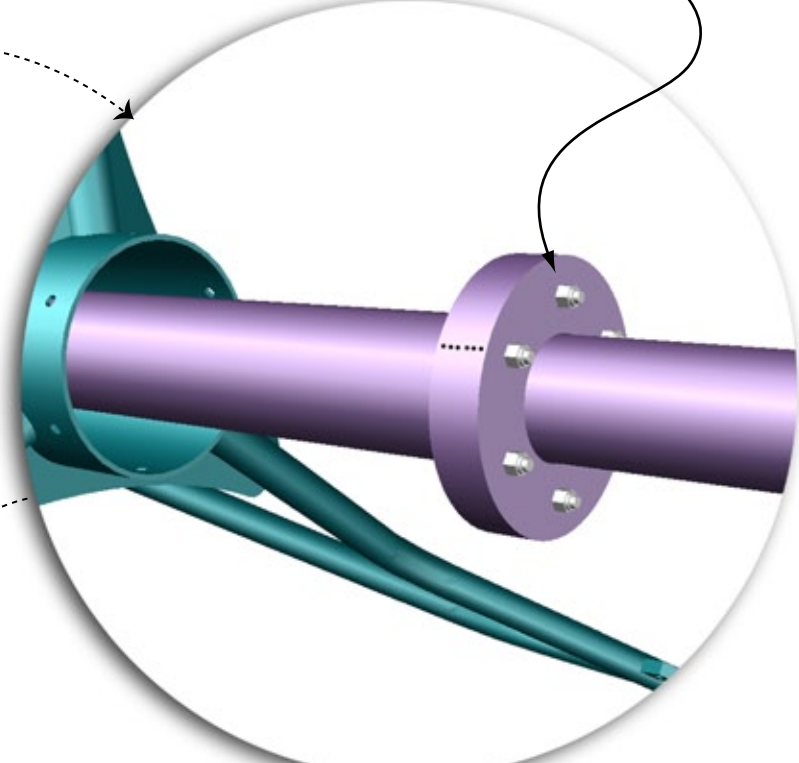
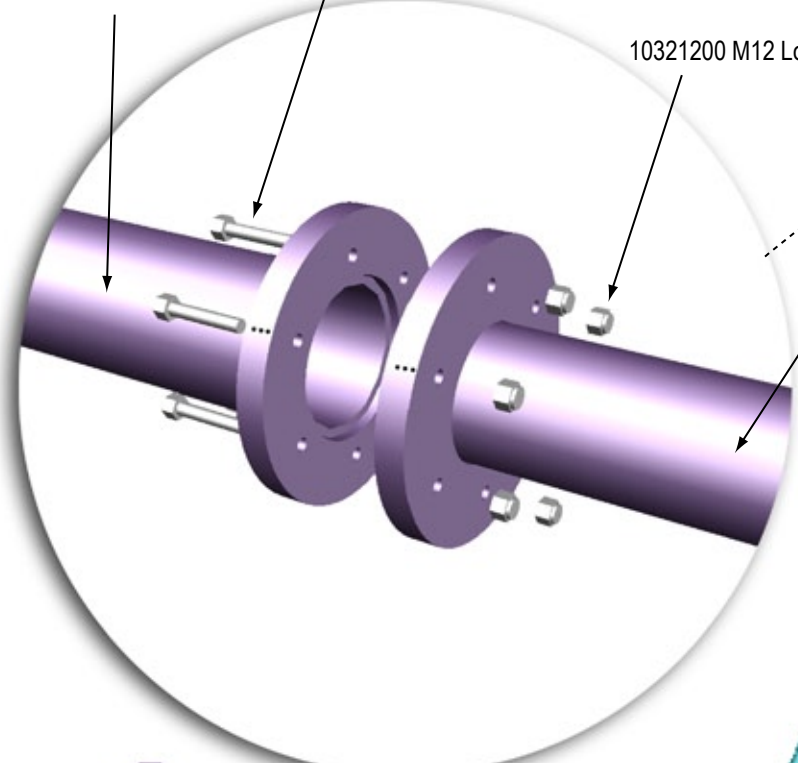

Prior to assembly ensure the serial number punched on the flanges match, if they do not ring (+44)1757 703620.

Ensure marks on both flanges are aligned on connection as per image left.

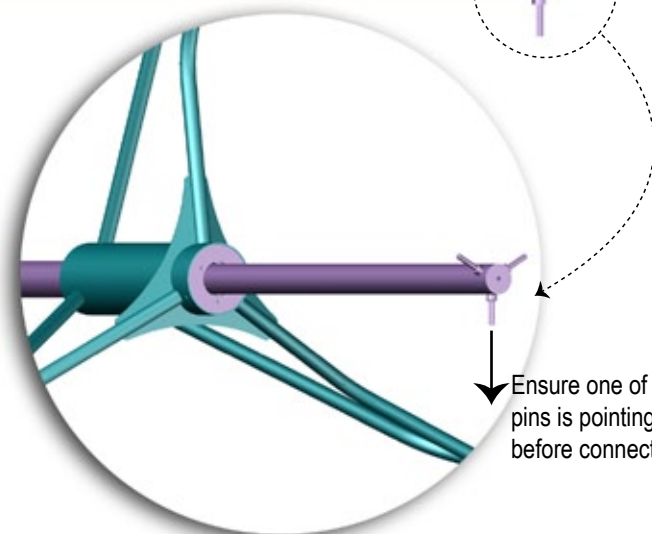

Ensure one of the threaded pins is pointing to the ground before connecting the 2 masts

RP404 Typhoon - Halo Ring to Wings Assembly

3 No 10121225 M12 x 25 Button Headed Socket Screws c/w 10381200 M12 Washers

Apply Medium Strength (Blue) "Nut Lock" to all 9 M12 Button Headed Socket Screws prior to fixing Halo rings in position

6 No 10121225 M12 x 25 Button Headed Socket Screws c/w 10381200 M12 Washers

IMPORTANT NOTE: ensure the 404110 Bobbins rotate freely prior to fitting the Halo rings inside the outer sleeve.

Attach the Halo rings to the Wing Arm in accordance with the illustrations on this page **PAYING PARTICULAR ATTENTION TO THE ORIENTATION OF THE UPPER HALO RING IN RELATION TO THE WING ARMS, SEE ABOVE RIGHT.**

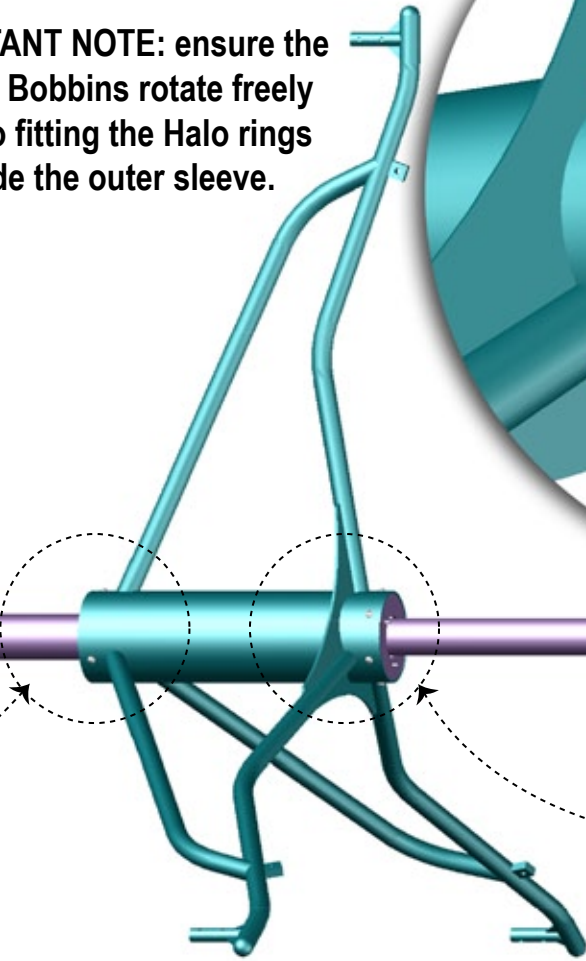
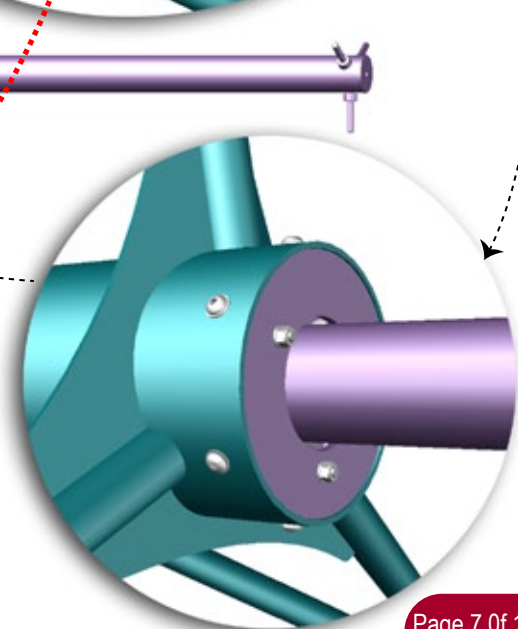
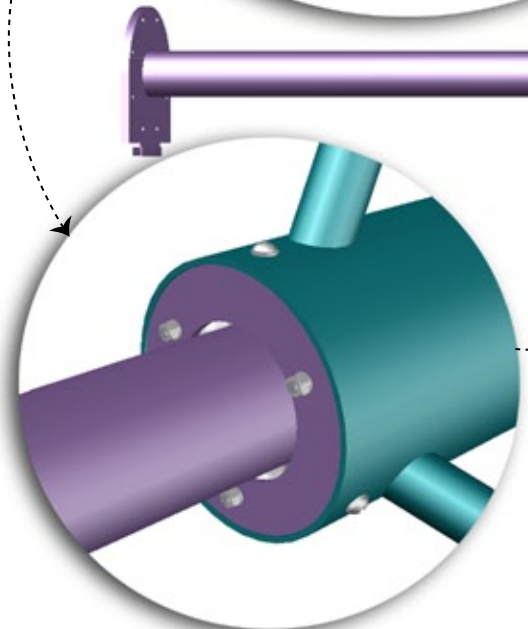
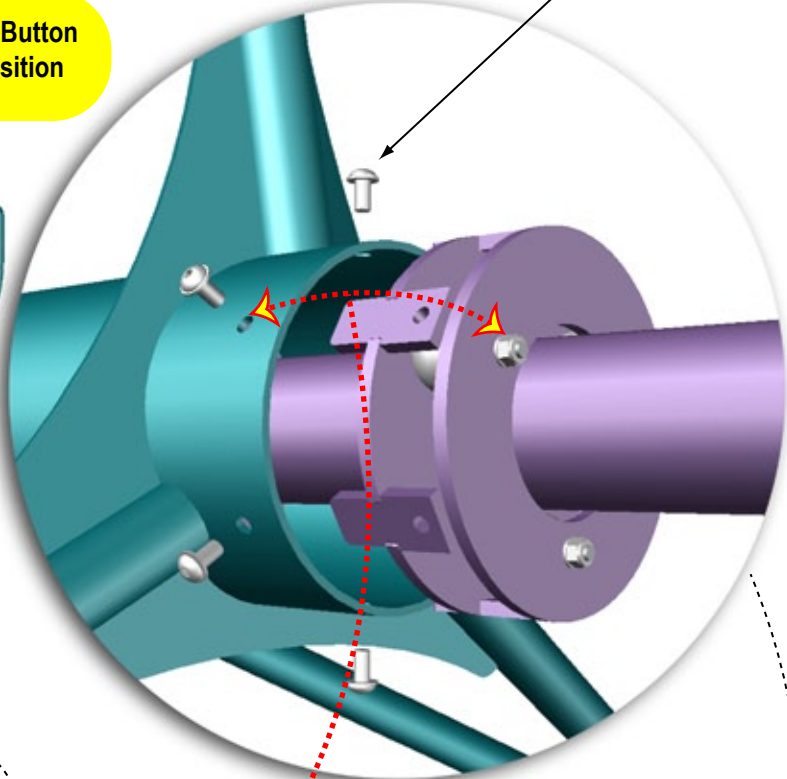
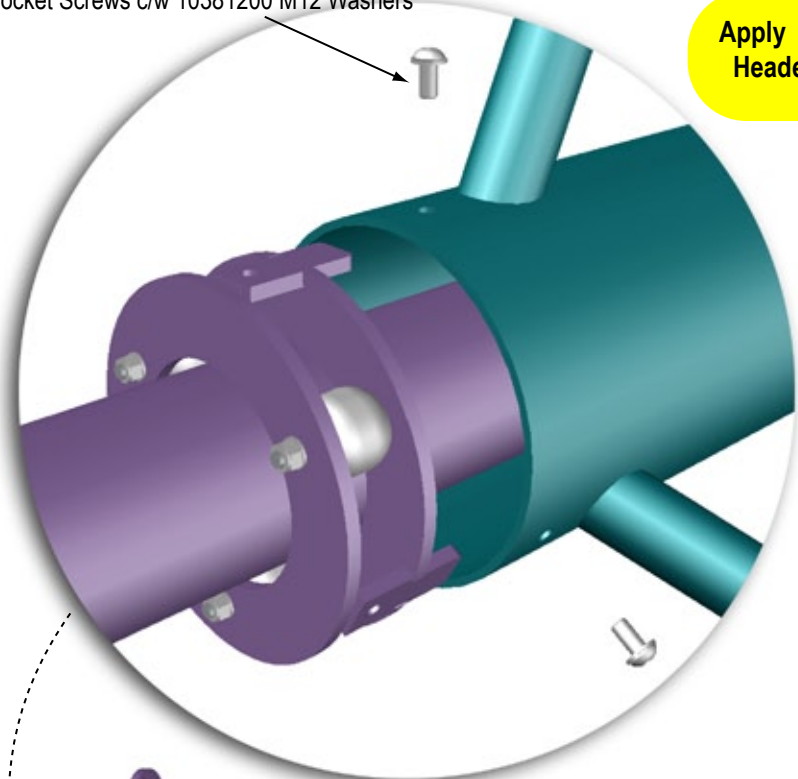



RP404 Typhoon - Suspension Rope Assembly 1 of 2

! NB: Ensure all 3 'Universal Joints' rotate freely **!**
! in all direction prior to erecting the assembly **!**

Assembly Sequence

1. Slide the Universal Joint end of the suspension ropes over the threaded pins of the upper mast
2. Screw down 3 of the PRISTINE M20 nuts (10332000) onto the universal joint block, finger tighten only
3. Screw the brace (404400) onto the top of the upper mast using 1 No M16 x 30 Hexagonal Headed bolt (10231640) and twist round to engage the pins
4. Screw the last 3 PRISTINE M20 nuts against the brace then fully tighten both sets of nuts against the brace

404112 Suspension Ropes (3 No)

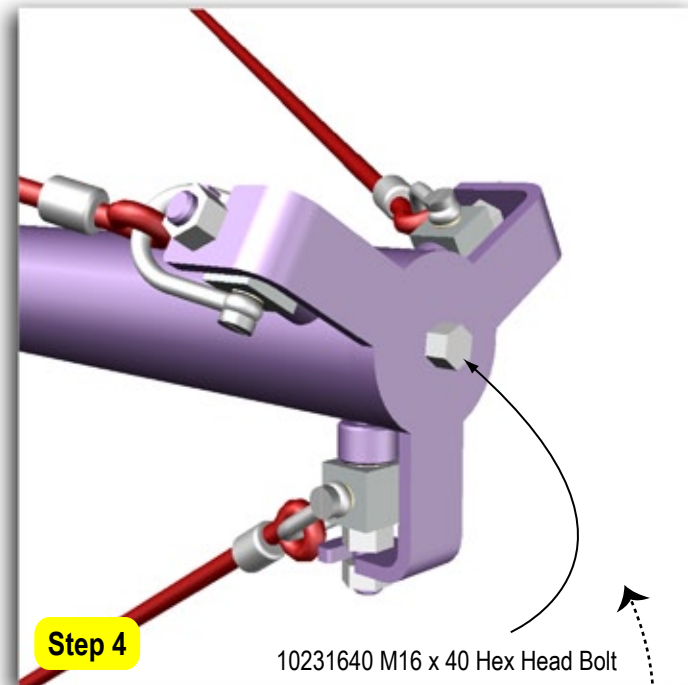
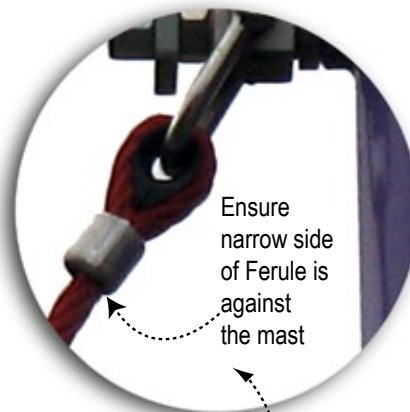
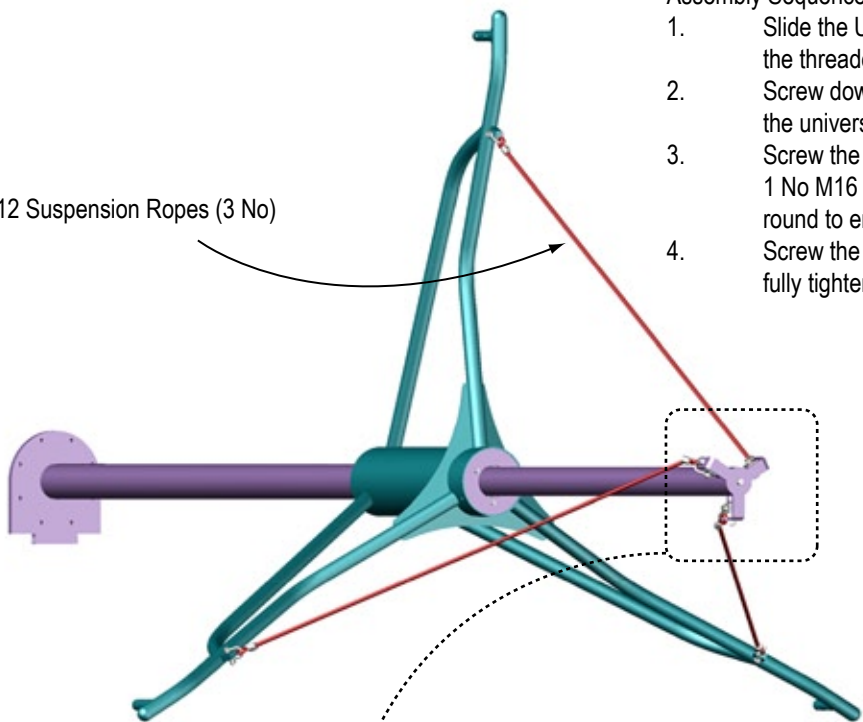

10231640 M16 x 40 Hex Head Bolt

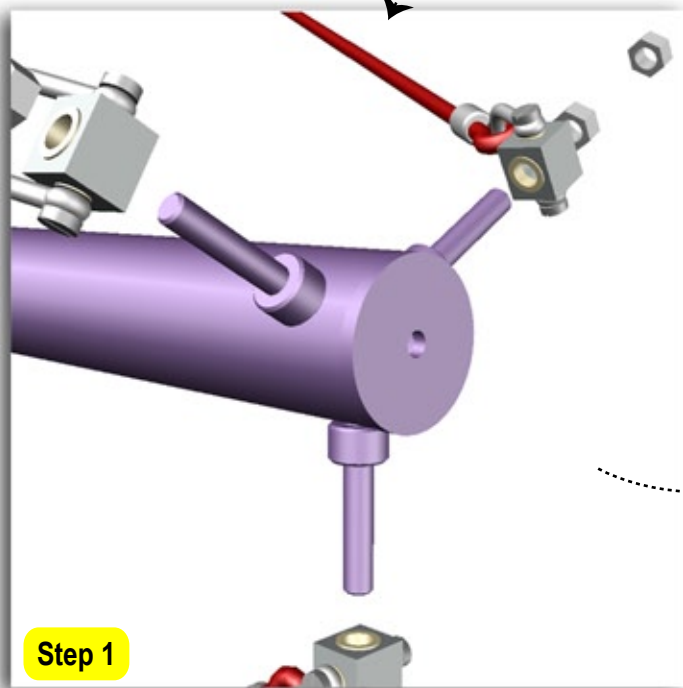

Step 1

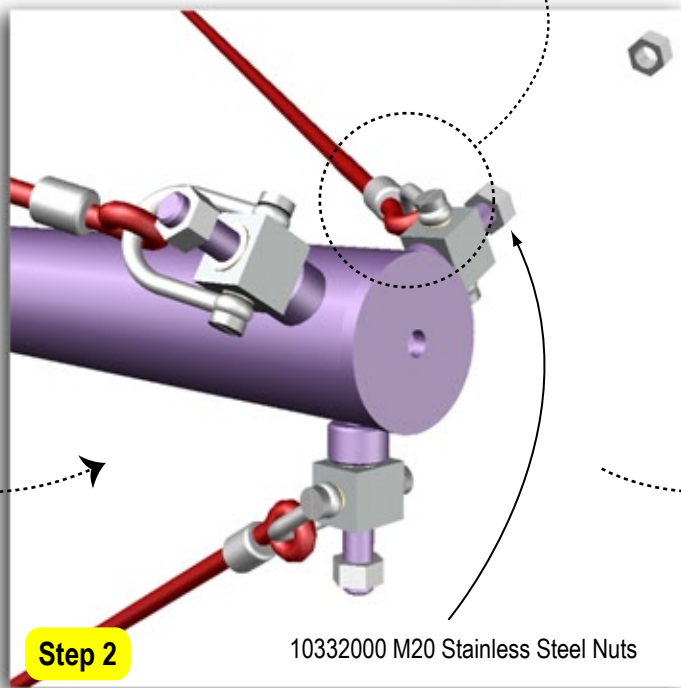

Step 2

10332000 M20 Stainless Steel Nuts

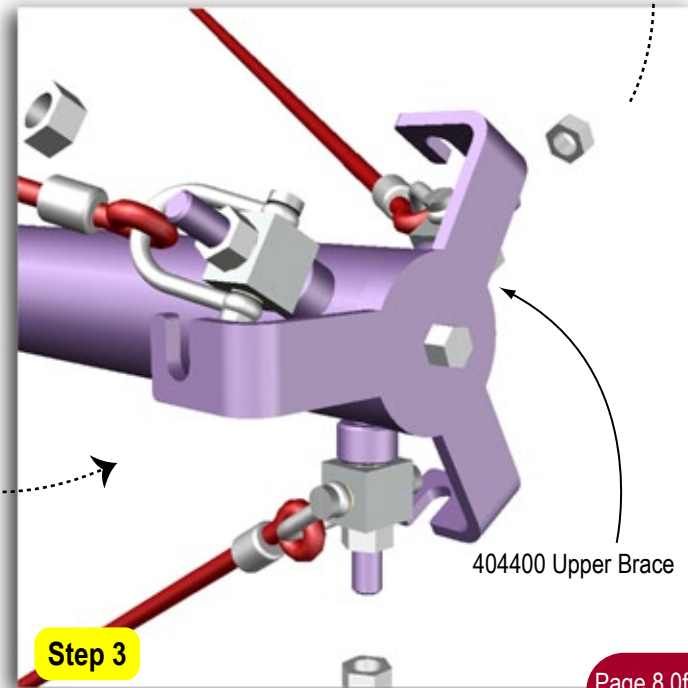

Step 3

404400 Upper Brace

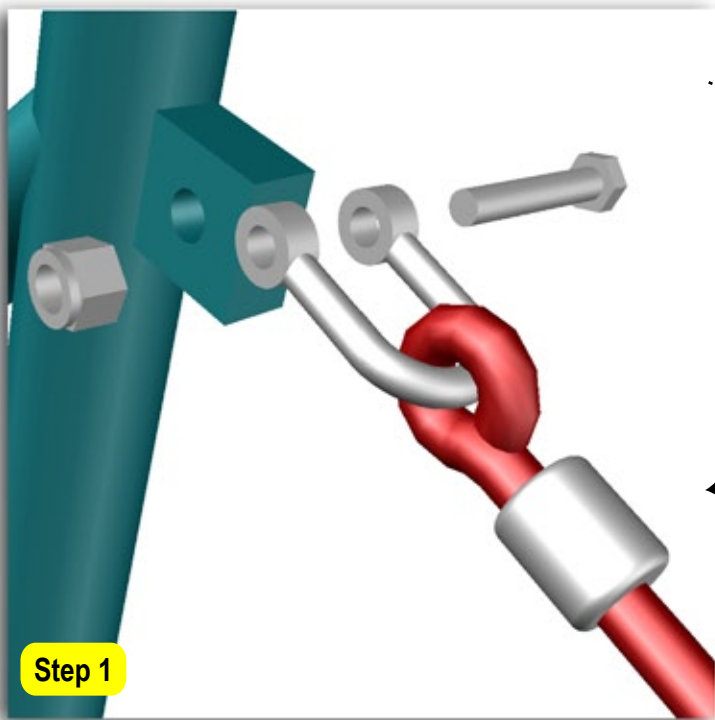

Assembly Sequence

1. Position the Shackle end of the Suspension ropes over the block on the wing arms.
2. Connect using the M12 shackle pin and fix using the M12 Lock nut.

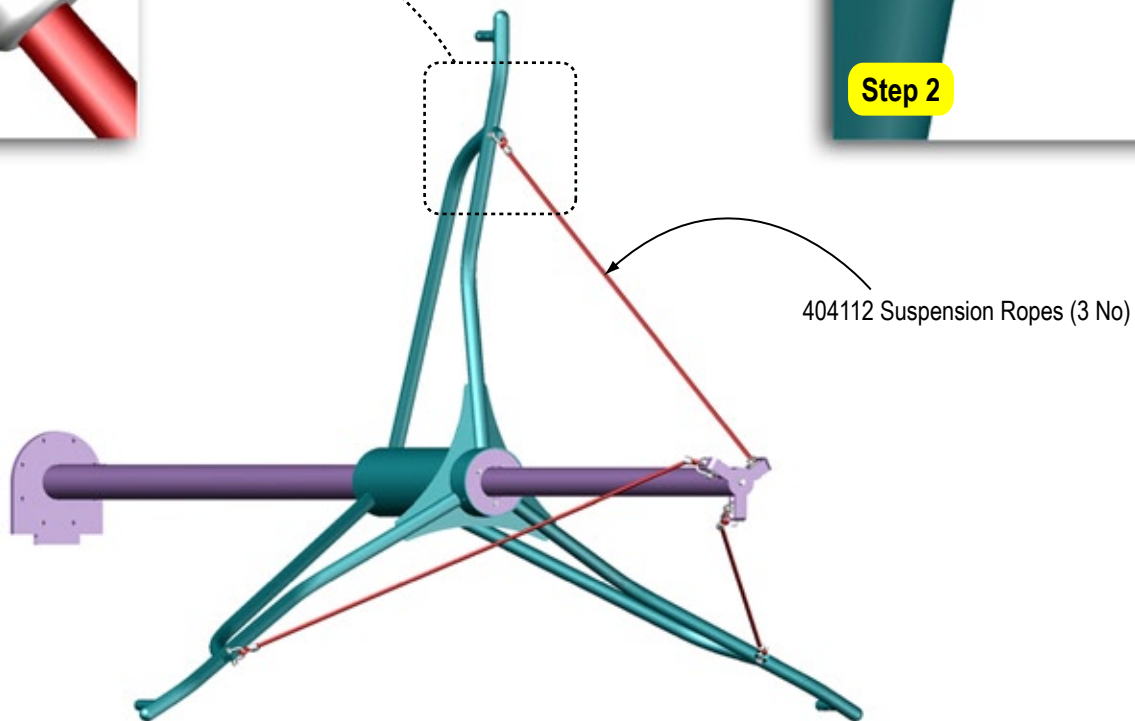
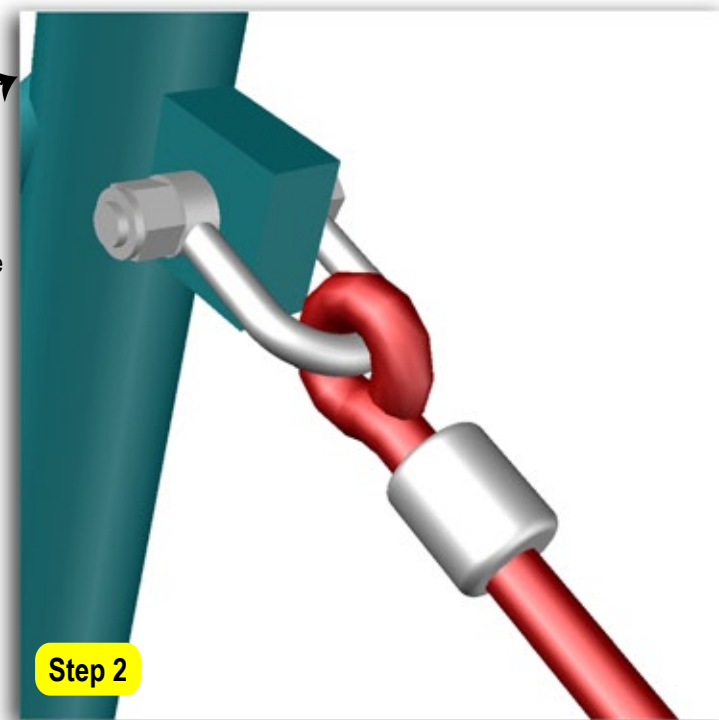



RP404 Typhoon - Hinge Assembly

404514 5mm Cotter Pins (2 No)

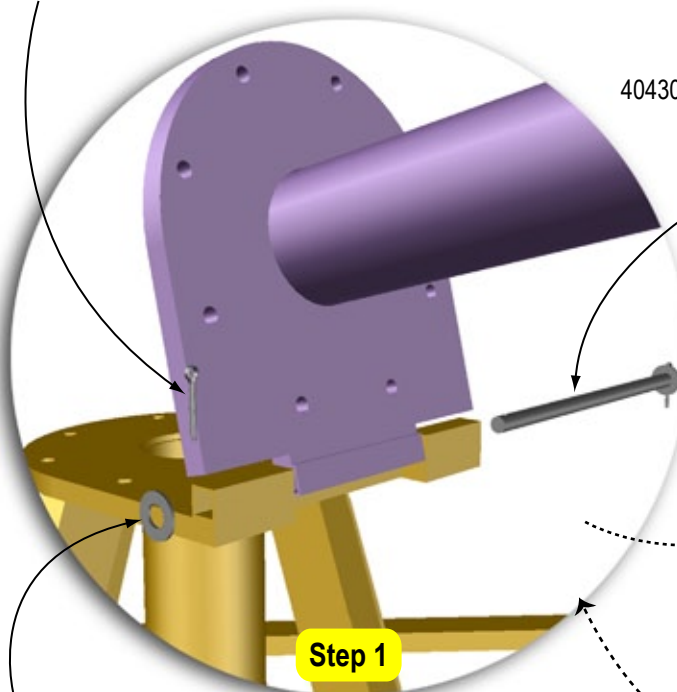

Step 1

404307 Hinge Pin

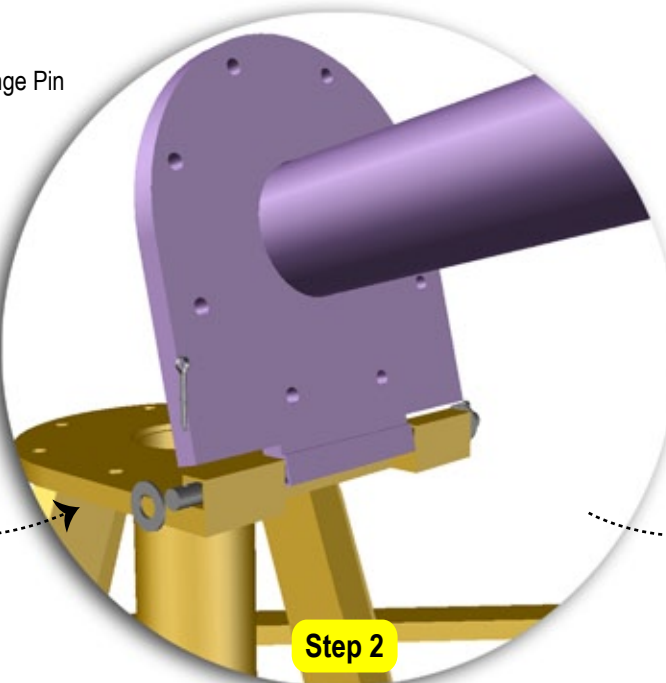

Step 2

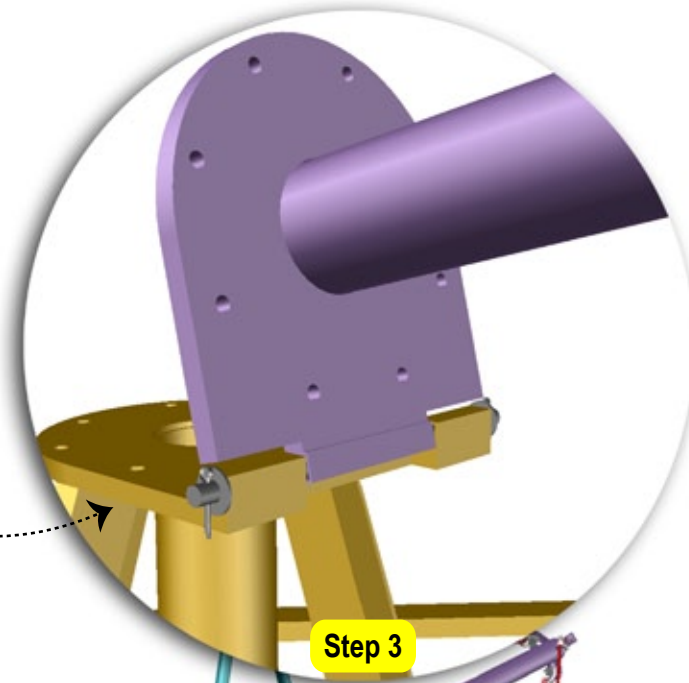

Step 3

10382000 M20 Washers (2 No)

Hinge Assembly Sequence

1. Fit M20 Washer (10382000) and Cotter pin (404514) to one end of the Hinge Pin (404307) and liberally apply grease to the pin.
2. Thread the pin through both flanges as illustrated.
3. Fit the remaining Cotter pins & Washer

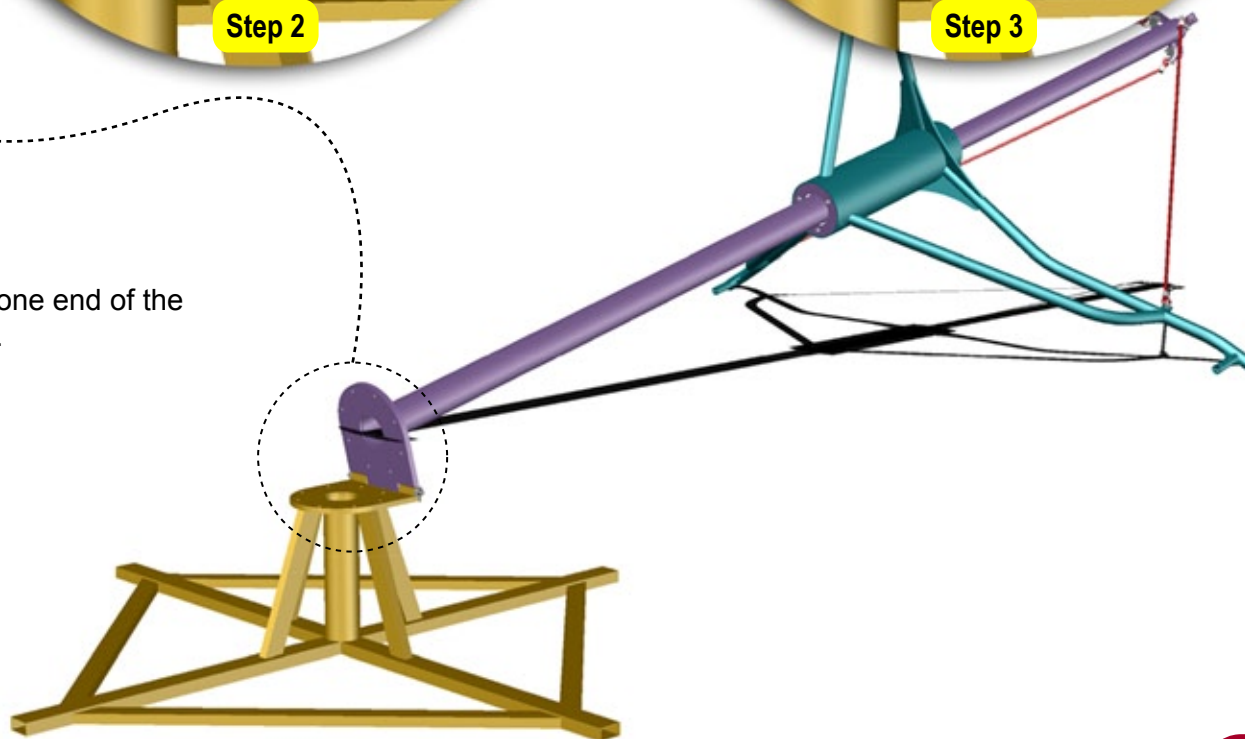



RP404 Typhoon - Erection

404305 Installation Aid c/w 404306 Clasps (2 No)

404513 Turnbuckle

Sling (not supplied)

Cable Puller

Anchor Point

Allow minimum 12m from anchor point to centre of Mast

Assembly and Erection Sequence

1. Assemble Installation aid to the top of the upper mast (approx 10cm from universal joint) using 2 No 404306 clasps c/w 4 No M12 x 50 Hexagonal headed bolts & 4 No M12 plain nuts. Ensure the surface of the mast is protected prior to fitting the installation aid
2. Attach the supplied turnbuckle and sling (Sling not supplied) and tighten the turnbuckle
3. Attach the Cable Puller (not supplied) to an appropriate anchor point
4. Attached the cable of the cable puller to the installation aid as illustrated
5. When you are satisfied everything is safe and secure begin winching up the assembled Typhoon
6. Once the assembled typhoon is in its vertical position, secure it to the base unit using 8 No M16 x 75 Hexagonal headed bolts c/w PRISTINE M16 Nyloc nuts - **Tighten using torque wrench to 200Nm.**
7. Disassemble the installation aids in line with best practice information provided



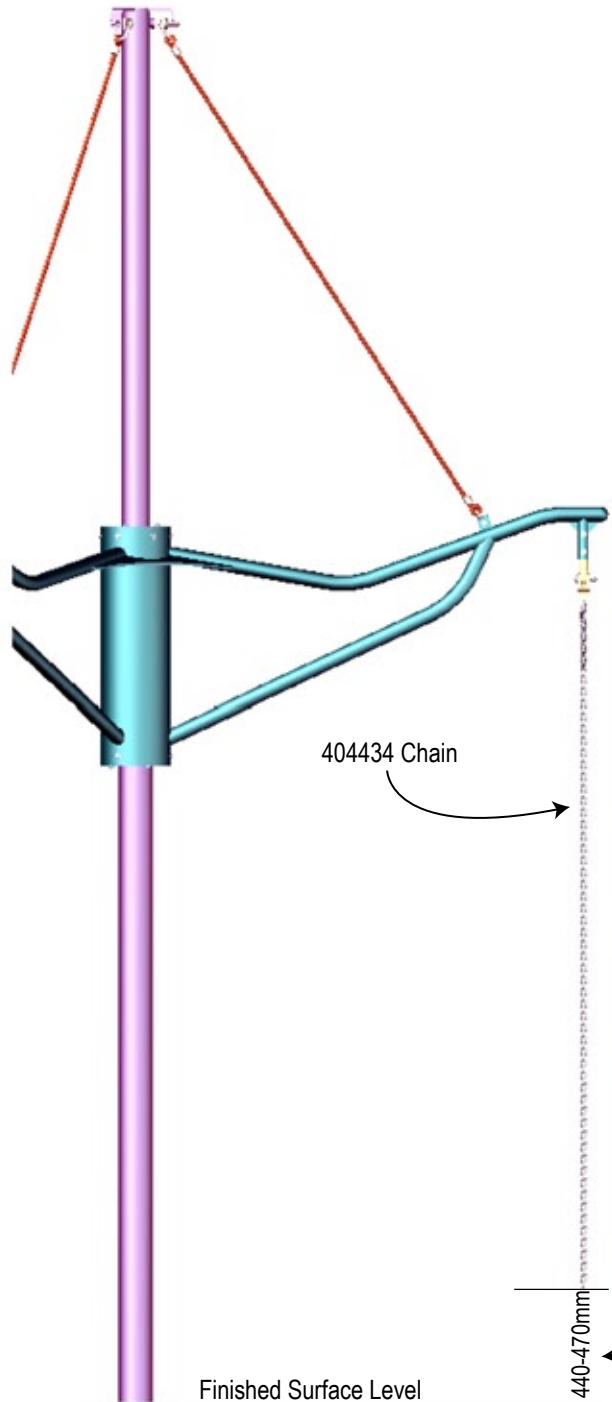

Step 1_ Fit Chain into socket (see page 13) and measure the distance from Finished Surface Level to the bottom of the chain. Adjust length of chain (Detach chain if necessary and use bolt croppers if required) to achieve the distance below left.

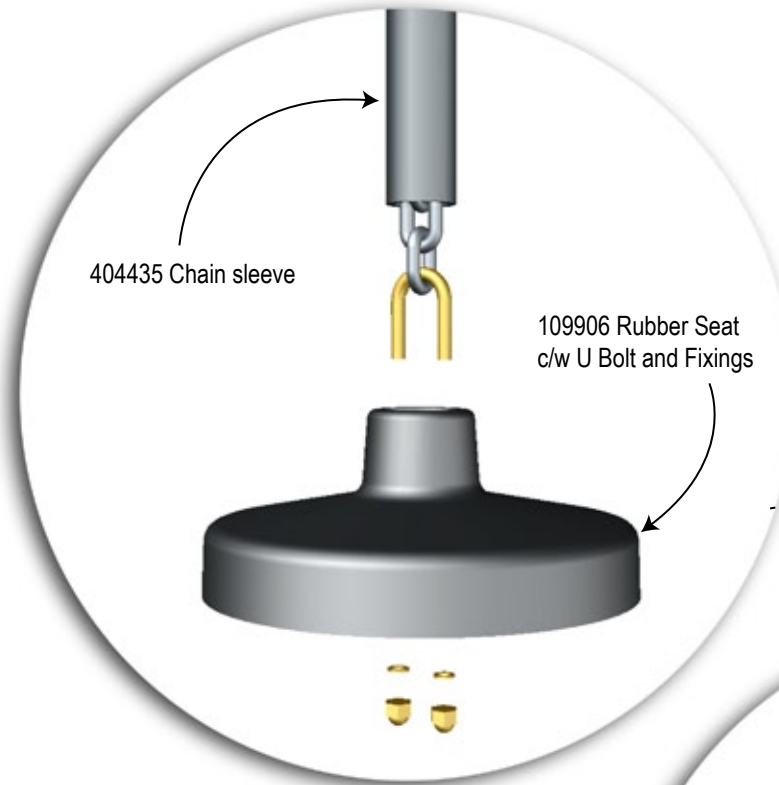

Step 2_ Once the chain is cut to the correct length slide 404435 Chain Sleeve over the chain, cut to length if necessary.

Step 3_ Attached 109906 to the bottom link of the chain using the U-Bolt and nuts and washers supplied Attached the chain to the Wing in line with page 13.

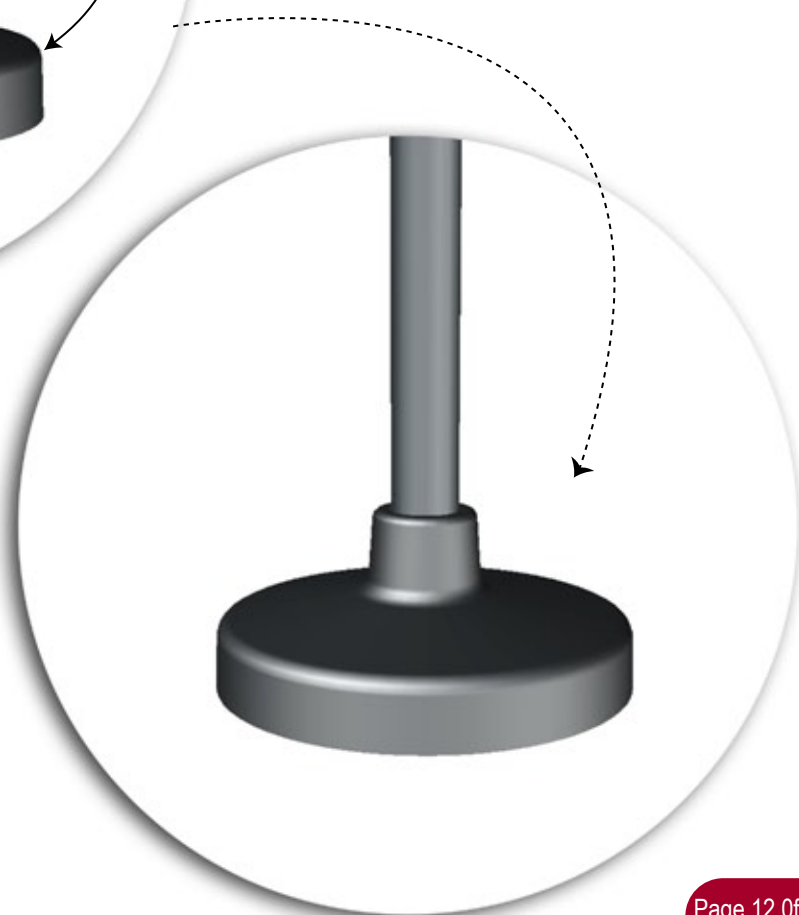

10281201 M12 Dome Headed Nyloc Nuts (3 No)

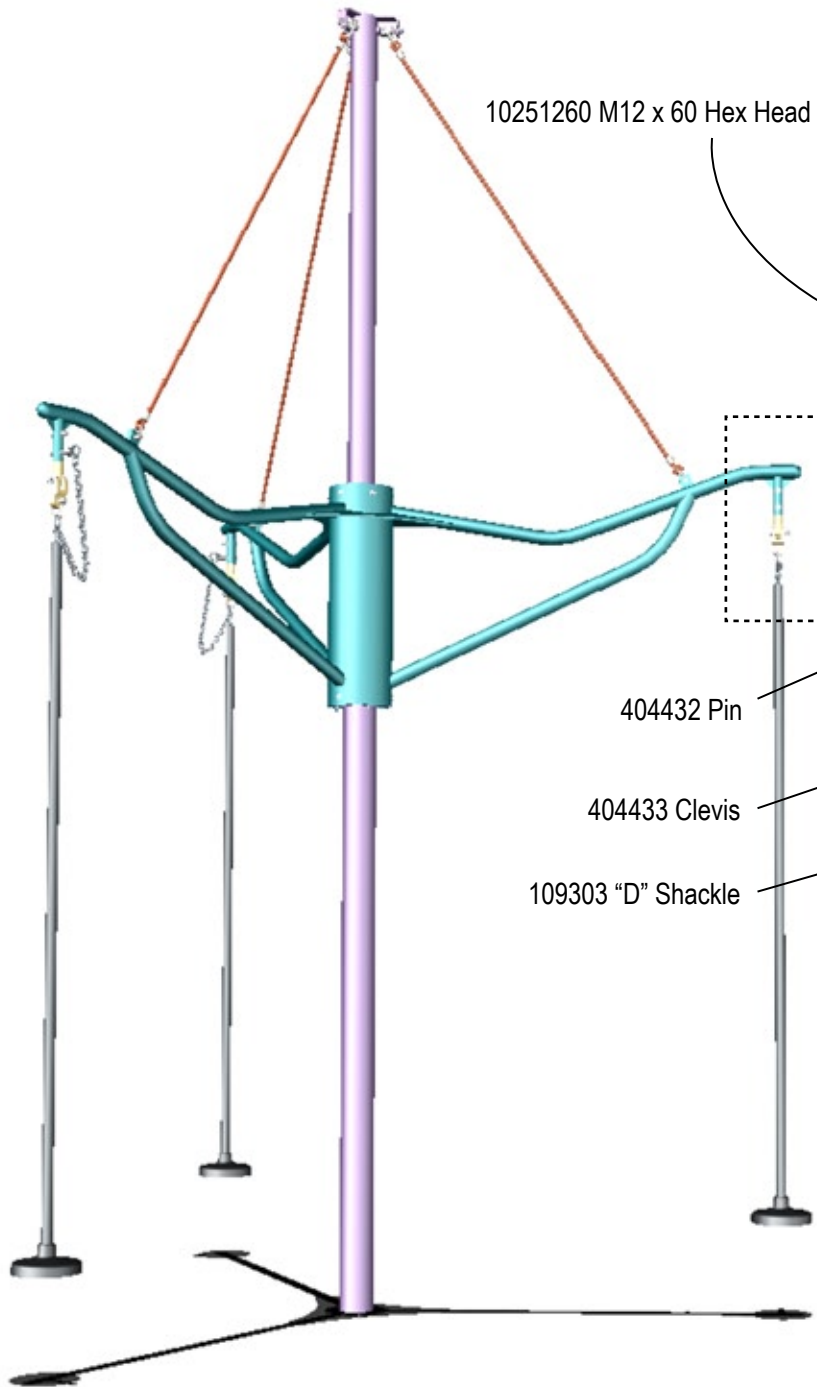

10251260 M12 x 60 Hex Head Bolts (6 No)

10381200 M12 Plain Washers

10271236 M12 Long Nut (3 No)

404432 Pin

404433 Clevis

109303 "D" Shackle

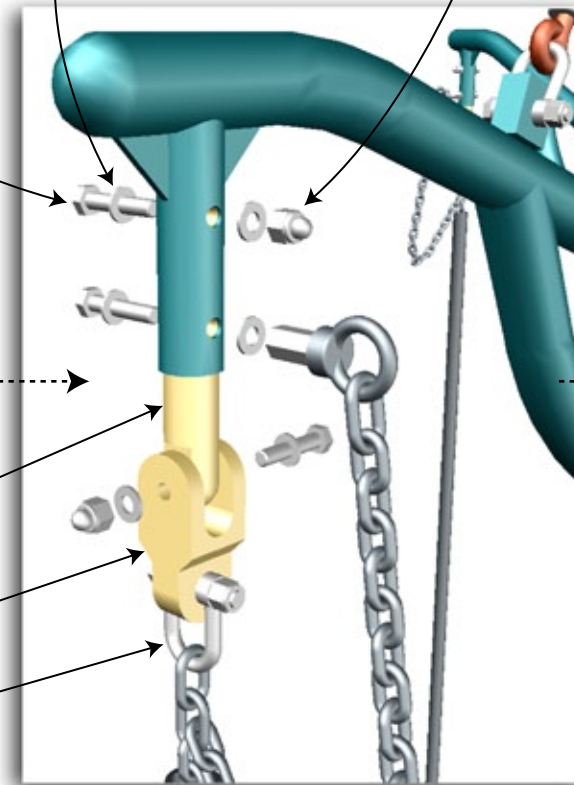

Step 1_ Assemble the Clevis (404433) and Pin (404432) using M12 x 60 Bolts (10251260) c/w Lock nut and washers.

Step 2_ Fit chain (404434) to Clevis using M12 Shackle (109303) c/w Lock nut.

Step 3_ Plug pin (404432) into the socket of the Wing Arm and fit the upper fixing - M12 x 60 bolts c/w M12 dome headed lock nut and washers.

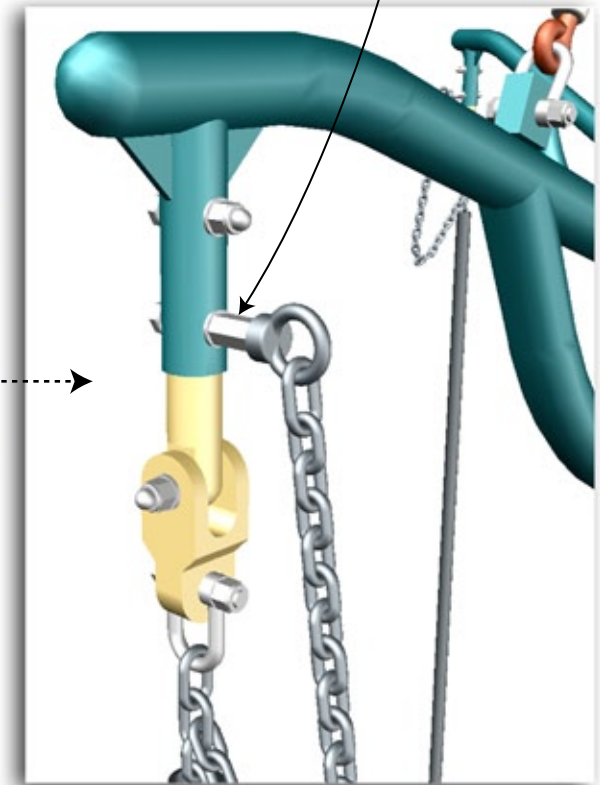

Step 4_ Fix the M12 long nut to the eye bolt of the Safety chain using Nutlock or similar.

Step 5_ Assemble the safety chain to the socket by fitting the long nut to the M12 x 60 bolt c/w washers. ensure the eye bolt of the safety chain is in the same orientation as the image above and secure the bolt using Nutlock or similar.



RP404 Typhoon Inspection & Maintenance Schedule

All play equipment should be maintained in accordance with EN1176 Part 7. The frequency of inspection will vary with the type of equipment or materials used and other factors, e.g. heavy use, levels of vandalism, coastal location, air pollution and age of equipment. Should you require additional information or assistance please contact our office on 01757 703620.

Routine Visual Inspection (WEEKLY)

- Check For:
- Structural integrity
 - Excessive wear of moving parts **paying particular attention to wear on the bobbins - to check push Wings against the mast and measure the gap between the mast and the internal diameter of the Halo rings adjacent to the bobbin fixture. If the gap is less than 5mm replace the bobbin. Repeat for all bobbins.**
 - Missing parts
 - Sharp edges
 - Exposed foundations
 - Inspect all ropes and ferrules for damage
 - Inspect seats and security of retaining rings for damage or stress
 - Ground clearances
 - Cleanliness
 - Ground surface finishes and surface condition

For playgrounds subject to heavy use or vandalism, more frequent, even daily, inspection is advised as above.

For playgrounds utilizing Loosefill Surfacing ensure level of surfacing is maintained at the appropriate level.

Operational Inspection (1 TO 3 MONTHS - *Ensure initial operational inspection is within the first month of use*)

- Check For:
- All the foregoing
 - No trip points or obstructions within the falling space
 - Check condition of column paint work particularly within sphere of wing arm travel
 - Check for signs of abnormality or binding of bobbins
 - Check for sings of lubrication within sphere of wing arm travel
 - Check operational function of all rope anchor points e.g. suspension rope top swivel connections
 - Inspect wing arms welds for signs of fatigue and wing arms for signs of over loading or abuse
 - Check structural integrity of the column as it enters the ground

Annual Main Inspection (NOT EXCEEDING 12 MONTHS)

- Check For:
- All the foregoing
 - Effects of weather
 - Rotting or corrosion
 - A change in the level of safety of the equipment as a result of repairs made, or of added or replaced components
 - Using an appropriate device, raise the wing arm to release the tension on the suspension ropes, inspect the upper column rope connection bushes, pins, fasteners and rope ferrules – replace any or all defective or suspect components
 - Ensure that the upper column swivel block is free to rotate and free from metal to metal contact.
 - Repeating above item 1 complete a full inspection of the wing arm connections/securing points.
 - Critically inspect all wing arm welds and wing arm for signs of overloading and/or distress.
 - Remove the six dome headed screws securing the Upper Halo, (noting the position of the bobbins relative to wing arms) inspect all three bobbins for security, excessive signs of wear, flats or other abnormalities and that they are free to rotate – if defective replace all three bobbins. Refer to installation for replacement instructions.
 - After completing item 5 above complete the same process on the lower Halo Ring.
 - Ensure all accessible fasteners are secure as per installation schedule.

Replacement Part Codes		
Code	Description	No Off
109303	DSR Galvanized "D" Swing Shackle	3
109906	Seat	3
404110	Bobbin Assembly	6
404112	Suspension Rope Assembly	3
404300	Lower Post	1
404301	Upper Post	1
404302	Wings	1
404305	Installation Aid (Flag Pole)	1
404306	Installation clasp	2
404307	Hinge Pin	1
404310	Base Unit	1
404400	Upper Brace	1
404432	pin	3
404433	Clevis	3
404434	Seat Chain	3
404435	Chain sleeve	3
404513	1032670 Turnbuckle	1
404514	Ø5 cotter pins - 30mm ling	2
10121225	M12 Button Headed Scket Screws	9
10231640	M16 x 40 Hex Head	1
10251250	M12 x 50 Hex Head	4
10251260	M12 x 60 Hex Head	6
10251271	M12 x 70 Hex Head	6
10251675	M16 x 75 Hex Head	8
10271236	M12 Long Nut	3
10271600	M16 Plain Nuts	8
10281201	M12 Dome Headed Nyloc Nuts	12
10321000	M10 Nyloc Nuts	12
10321200	M12 Nyloc Nuts	6
10321600	M16 Nyloc Nuts	8
10331200	M12 Plain Nuts	4
10332000	M20 Plain Nuts	6
10381000	M10 Plain Washers	24
10381200	M12 Plain Washers	45
10381600	M16 Plain Washers	16
10382000	M20 Washers	2

Typhoon Assembly and Installation Check List

The following check list references pages from the Installation guide and is intended specifically for contracts Managers to ensure key parts of the Typhoon assembly and installation are carried out correctly by installers during the installation. It should be noted that the list below does not add anything to what is already present in the guide and the guide should be considered the primary source of information pertaining to the correct installation and assembly of the Typhoon.

- Assembly Preparation (Page 4)** Ensure the Installers have all the correct tools and equipment necessary for the assembly and installation of the Typhoon as detailed on page 4 of the installation guide paying particular attention to the following: -
 - Torque Wrench "**and the knowledge of how to use it correctly**"
 - Tube of Medium strength (blue) Nutlock
 - Cable puller (Turfer) with a minimum capacity of 1.2 Metric tons c/w 20m Cable
 - 2 tonne "D" Shackle for attaching lifting device
 - 2 slings separately rigged to provide a 2 metric tonne pull
- Halo Ring Assembly (Page 5)** - ensure that when assembling the Halo Rings the M10 washers are correctly positioned as illustrated, and upon completion of the assembly make sure they are able to rotate freely.
- Mast Assembly (Page 6)** – Ensure that the masts are a matched pair by making sure the serial number punched on the flanges are identical. If they are not contact the production dept immediately
- Mast Assembly (Page 6)** – Ensure that when the flanges are connected the dots punched on the flanges are aligned adjacent to each other, this is to ensure a plumb mast when erected.
- Mast Assembly (Page 6)** – it is imperative that the upper and lower mast connection is made with the correct **PRISTINE** fixings and that these fixings are tightened to the torque setting specified of 150Nm.
- Halo ring to Wings Assembly (Page 7)** – Prior to connecting Halo Rings to the Wings ensure once again that the bobbins are completely free to rotate on their shafts.
- Halo ring to Wings Assembly (Page 7)** - The M12 x 25 button headed socket screws used to fix the Halo rings inside the sleeve of the Wings must have Blue Nutlock applied.
- Halo Rings to Wings Assembly (Page 7)** – Ensure the orientation of the upper halo ring is exactly as per the illustration on page 7
- Suspension Rope Assembly 1 of 2 (Page 8)** – Ensure the Universal Joints are free to rotate in all directions
- Suspension Rope Assembly 1 of 2 (Page 8)** – Ensure the ferule is positioned against the mast as per the inset photograph in the middle of the page.
- Suspension Rope Assembly 2 of 2 (Page 9)** – Prior to fitting the 12mm Shackle ensure the Oilite bush is pressed in the block of the Wing Arm, after fixing the shackle ensure it is free to rotate on the bush.
- Erecting the Assembly (Page 11)** – Once fully erect, it is imperative that the correct **PRISTINE** fixings are used to connect the base unit flange to the lower mast flange and that they are tightened to the prescribed torque setting of 200Nm.

Date _____ Signed _____ Contract No _____